



NEW REGENERATOR DESIGN FOR REGENERATION OF RAW COTTON VOLES FROM NON-GINNED SEEDS

Yuldashali Ergashov

Candidate of Technical Sciences, Docent, Department of Natural Fibers,
Fergana Polytechnic Institute, Fergana, Uzbekistan

E-mail: yuldashaliergashov@gmail.com

Malikakhon Babayeva

Assistant, Department of Natural Fibers, Fergana Polytechnic Institute

Abdulatif Akhmedov

Master's student, Department of Natural Fibers, Fergana Polytechnic Institute

Abstract

This article provides information about the operating parameters and efficiency of regeneration, a new design of a regenerating device for under-ginned seeds, before the linting process.

Keywords: seeds, under-ginned seeds, saw drum, feeder, needle drum, brush drum. Our country is one of the world's leading producers and exporters of cotton. That is why the cotton growing and processing industry plays an important role in the country's economy.

Introduction

Uzbekistan mainly produces hairy and dehydrated seeds. In recent years, low-hair seed technology has also been introduced. Seed production is carried out in accordance with the "Technological regulations for the processing of raw cotton and seed production." The regulations define the basic requirements for the technology of preparation of hairy, mechanically dehaired and low-hairy seeds, including the process of treatment and coating.

The main technological process of ginneries, which is the process of separation from fibrous seeds, determines the characteristics of the output of seed cotton.



If the process of fiber separation from the seeds is carried out as required, and the transfer of seeds from the separated seeds with spinning fibers to the technological process of separation and re-ginning will increase the share of fiber yield of seed cotton.

The Main Part

Currently, RNS regenerators are used in ginneries. The structure of the seed regenerator RNS with incompletely separated fibers is shown in the figure. and a brush separation drum (6). The operating mode of the regenerator is based on the interaction of the separated fibers with the saw teeth of the rotating drum (3). [1]

It is regenerator USM-A can be installed after the pneumatic seed cleaner or after the elevator before lintering on the distribution auger head. The main indicator of the regenerator is that in order to completely separate the fibers in the regenerated seed, ie the fiber in the seed, the above RNS device is replaced by a needle drum instead of a drum. the device has been improved to increase regeneration efficiency. The working dimensions of the needle drum have been developed and constructed.

The device consists mainly of a rotary drum with a saw set and a brush drum to separate completely unfertilized seeds from the seeds and transfer them to the ginning process. But today, as new generations of cotton selections are created, it also affects some of the processes of the seed cotton processing plant.

The results of scientific research show that this condition has a greater impact on the technological processes of ginning, leading to an increase in the number of fibrous seeds in the fiber separated from the seed.

Therefore, it is necessary to improve the device that separates the fibrous seeds from the contaminated seeds. Therefore, the design of the RNS regeneration device currently in use was developed. (Figure 1)

The proposed structure regenerates the seeds that are lifted by an elevator into the flow of processes that transmit the seeds from the demon through this structure and then transferred to the linter machines.

The seeds are picked up by a needle drum, and the fibrous seeds attached to the surface of the needles are removed with a drum brush and passed to the ginning process.

The fibrous seeds in the needle drum allow for complete separation from the saw blades used.

The design of the main working parts of this device has already been developed, and the first experimental tests are planned.

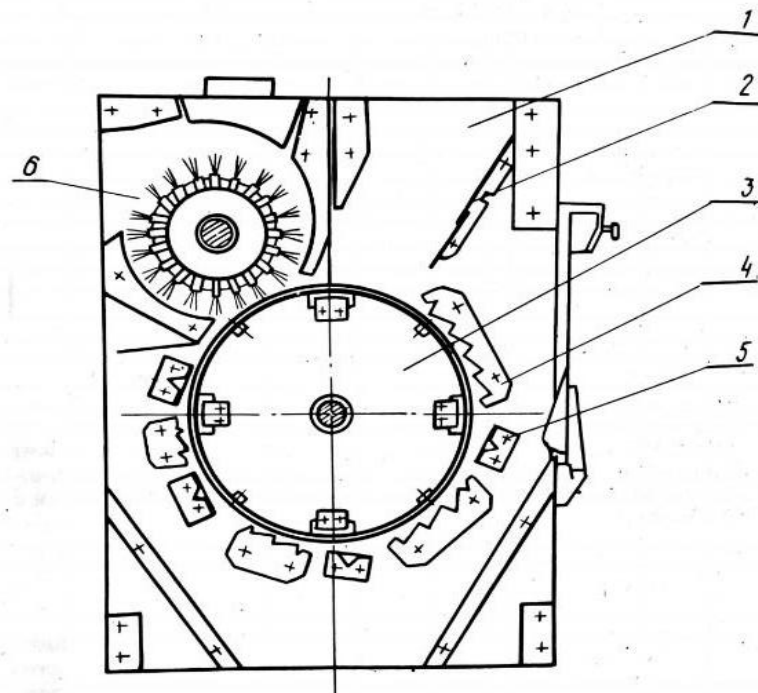

Figure1. 1-supply line, 2- router, 3-saw drum, 4- kolosnik cage , 5- router, 6- brush drum

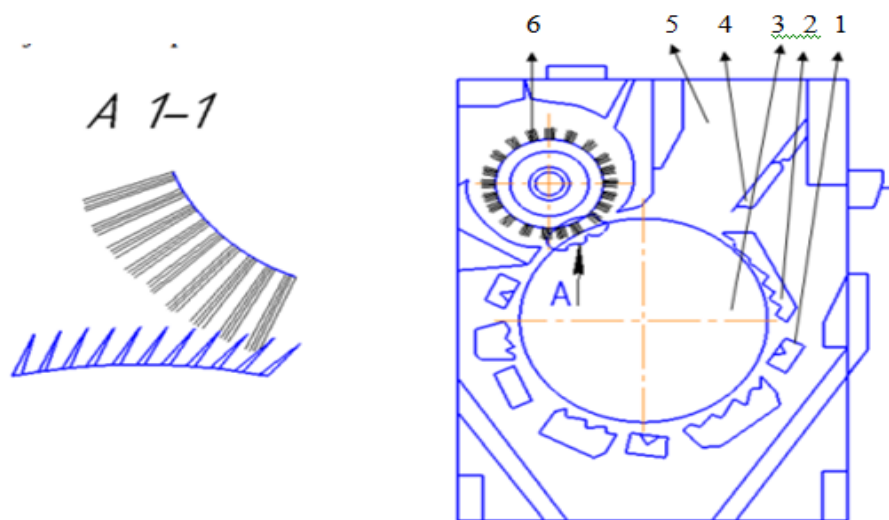

Figure 2. 1-Supply pipe , 2- guide , 3-needle, 4-column grate, 5-guide, 6- brush



Conclusion

The main indicator of regenerators is the regeneration efficiency, which is determined by the amount of fiber in the fiber, which is not separated from the fiber, or the amount of regenerated fiber.

Adjustment of the regeneration process is carried out by changing the technological holes of the regeneration device, depending on the initial quality parameters of these seeds. The results of the application of the advanced regeneration device fully meet the above-mentioned characteristics, the technological gaps, ie the distance between the supply drum guide and the needle drum to 20-50 mm, the spacing of the needles with the grate by adjusting to 13 ± 2 mm, regeneration efficiency is increased by 33%.

References

1. E. Zikriyoyev Paxtani dastlabki qayta ishlash Toshkent. "Mexnat" 2002-yil
2. R. A. Gulyayev , A.E. Lugachev, X.S. Usmanov Современное состояние производства, переработки, потребления и качества хлопковой продукции в ведущих хлопкосеющих странах мира. Tashkent-20173-4b.
3. O.Sh.Sarimsakov, D.U.Turg'unov, M.N.Babayeva "The Velocity Distribution over the Cross Section Pipes of Pneumatic Transport Installations Cotton" "Middle european scientific bulletin" ISSN 2694-9970
4. <http://mrit.academiascience.org/index.php/mrit/issue/view/2>
5. D.U.Turg'unov, M.N.Babayeva "Verification of the values obtained based on the theoretical analysis of the working details of the crusher in the program "Solidworks" ACADEMICIA: An International Multidisciplinary Research Journal
6. <https://www.indianjournals.com/ijor.aspx?target=ijor:aca&volume=12&issue=10&article=038>