



EQUIPMENT FOR CLEANING COTTON FROM FINE CONTAMINANTS

N.M. Oripov

Doctoral Student, Fergana Polytechnic Institute, Fergana, Uzbekistan

A.A. Abduqaxorov

Master's Degree Student, Fergana Polytechnic Institute, Fergana, Uzbekistan

S.B. Uzaqova

Assistant, Fergana Polytechnic Institute, Fergana, Uzbekistan

Abstract

The article examines the structures of cleaners describing the separation of large and small weed impurities from the cotton mass, will determine the parameters for calculating the cleaning effect of having an elastic bond with cotton.

Keywords: cotton, technology, dirty, theory, equation, force, model, fiber.

Introduction

The optimal number of working bodies for pile and saw drum cleaners is 6-14 and more, and its further increase does not increase the cleaning efficiency. At the same time, the number of drums in the pile drum cleaner, which is the first cleaner in the technological process, does not exceed 6 when cleaning low-grade raw cotton. It should also be taken into account that the harvesting of seed cotton by machine harvesting leads to an increase in the amount of contaminants in it. The degree of contamination of raw materials collected in machine harvesting is from 8% to 30%; and higher, mostly picked with a cotton swab. This underscores the need to improve the technique and technology of ginning cotton before the ginning process [1-3].

In the current available technologies, after ginning, the seed cotton is cleaned from small impurities and then from large impurities. Pile drum cleaners are used for cleaning small contaminants, and sawdust drum cleaners are used for large contaminants. Considering that mechanical cleaning can damage the fiber and seeds, great attention is paid to the selection of the optimal number of seed cotton and fiber cleaning (the number of cleaning refers to the number of saw drums involved in cleaning the seed cotton) [4-9].



This can be understood as follows. Experts have obtained graphs of the dependence of fiber classes (varieties) on the number of cleaning drums when changing the appearance of fiber by hand and machine-picked cotton. The fiber class (type) increases significantly when the number of cleaning drums increases from 1 to 6; As it increases from 6 to 12, the cleaning intensity decreases. Further increase in the number of drums does not lead to an improvement in fiber quality Table 3.12. However, as the number of cleaning drums increases, the quality of the fiber deteriorates as a result of the negative impact of the mechanical processing of the fiber. If the number of cleaning drums is not increased too much when processing for machine-picked cotton, the deterioration of the appearance of the fiber will not be noticeable. As the number of cleaning drums increases, the appearance of the fiber deteriorates the micronaire performance. It is necessary to minimize the mechanical impact on the process by maximizing the cleaning of the technological process of processing of seed cotton with the working bodies, as well as the rational placement of cleaners and reducing the number of transport devices [10-16].

The Main Part

Experiments were conducted to study the impact of fiber on quality indicators as a result of increasing the number of drums for cleaning raw cotton in the coordinated technological process of the enterprise. The test used And-35, a variety of raw cotton, its initial quality indicators: industrial grade III, class 2, moisture 12.5%, impurity 11.9%, maturity 0.7%, the degree of mechanical damage to the seed 1.5% (Table 1).

Table 1. The following table shows the interaction between fiber qualities as a result of the increase in the number of cleaning drums.

Selection industry	Mechanical of seeds %	damage	Short fiber content %			Staple fiber, mm	weig ht	length of		Mass of defective and dirty mixtures,%		
			%	%	%							
Types												
Types	4	8	12	4	8	12	4	8	12	4	8	12
C-6524 II/2	1.9	1.9	2.1	7.7	7.7	7.9	32.4	32.2	32.2	2.3	2.3	2.4
And-35 III/2	3.7	3.8	3.9	9.5	9.0	9.8	31.3	31.2	31.1	3.9	3.9	3.9
And-35 IV/2	5.1	5.1	5.6	12.	12.5	12.2	30.4	30.1	30.0	8.5	8.6	8.7

Mechanical damage to the seed%, short fiber content%, fiber staple length mm in mm, mass fraction of defective and dirty mixtures%, when the number of cleaning drums is 6-8-12 in different selection varieties of raw cotton, with a working capacity of 5 tons / hour, the following are shown in the graphs (Figure 1.).

The selected raw cotton in each selection and industrial varieties was carried out 3 times on experimental equipment, samples of raw cotton cleaned in the technological process were taken and laboratory analysis was carried out.

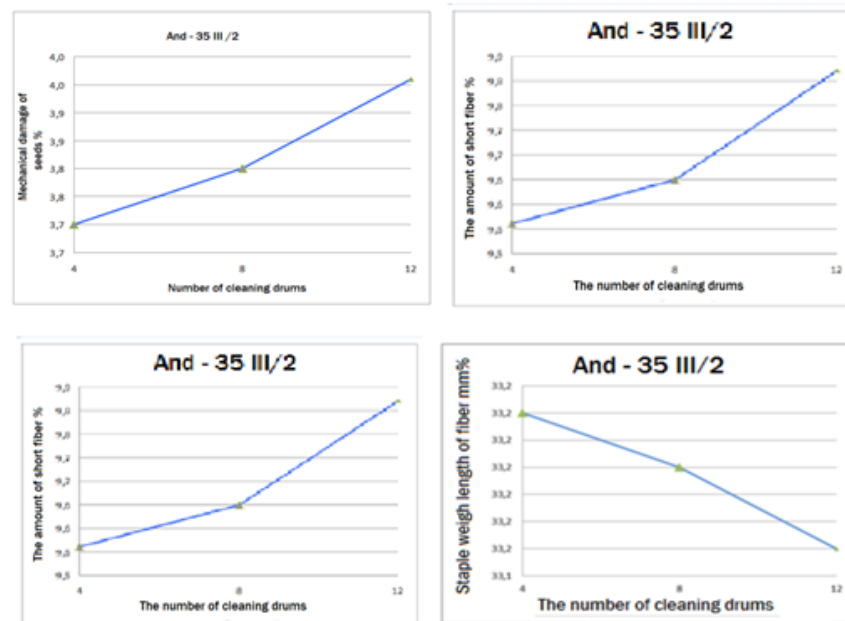

Figure 1. Mechanical damage to the seed, the amount of short fiber, the staple weight length of the fiber in mm, the mass fractions of defects and contaminants are given.

The results of the analysis show that the effect of cleaning frequency on cleaning performance at different work efficiencies is shown in the graph, when the number of drums for cleaning raw cotton increases from 4 to 12 at 5 t / h, mechanical damage to seeds from 3.70% to 3.96%; short fiber size, 9.51% to 9.82%; staple weight length of fiber from 31.35 mm to 31.15 mm; the mass of defective and contaminated compounds increased from 3.90% to 3.99%. Subsequent experimental work used S-6524, II-nav.2-class.2 grade raw cotton, its initial quality indicators: moisture 10.5%, contamination 9.6%, mechanical damage to the seed 1.90, from 1.98%; short fiber miklori, from 7.70% to 7.93%; staple weight length of fiber from 32.40 mm to 32.20 mm; the mass of defective and contaminated compounds increased from 2.30% to 2.47% [17-21].

And-35, IV-nav.2-class cotton raw material variety was used, its initial quality indicators: moisture 14.5%, contamination 15.5% mechanical damage of seeds from 5.10,% to 5.63%; short fiber miklori, from 12.50% to 12.72%; staple weight length of fiber from 30.45 mm to 30.05 mm; the mass of defective and contaminated compounds increased from 8.50% to 8.76%.

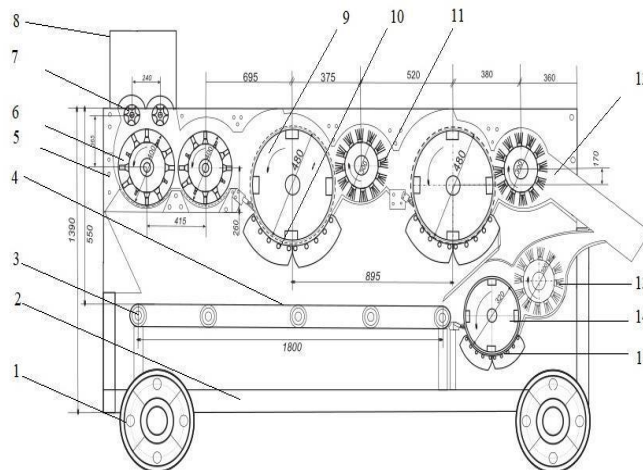

Figure 2. Schematic diagram of a cotton cleaning machine..

1 wheel, 2 device base, 3 collecting tape, 4 rollers, 5 mesh surface, 6 pile drum, 7-pile supplier, 8-pile receiving hopper, 9-ply drum, 10-ply grate, 11-ply drum, 12-pound cotton pipe, 13-ply drum, 14-ply drum, 15-ply ribbed grid.

When analyzing the results obtained, we can see a decrease in quality indicators as a result of mechanical processing of raw cotton and its fiber products in the coordinated technological process of the ginnery. It is obvious that in the cleaning of low-grade and high-pollution cotton is the maintenance of quality and the introduction of its technology.

Flow 1-XP (RX-1), EN 177 saw sections, UXK cotton ginning units. The EN 177 saw section is the main part of the 1XP ginnery and 1RX regenerators, and high-impurity cotton raw material is fully processed by this technological process.

To clean the normal cleaning sections of cotton, the 3UXK unit with parallel-mounted cotton cleaning units is combined, the interchangeable UXK has 6 sections, 6 pile connections and 1 XK cleaner located in the last block.

The research and testing was carried out on the basis of the "Coordinated Technology of Cotton Processing (PDQI-2016)", which has been used in the ginning industry of the Republic of Uzbekistan since 2016.

Table 3. Structural quality indicators of cotton fiber obtained from production according to the sequence scheme of the technological process

Sequence diagram of the technological process		Composite quality indicators of cotton fiber obtained from production						
		Breeding and industrial grade S-6524 II / 2						
		Starting pollution %	Total defects,%	Minor pollution %	Ulyuk%	Broken seeds%	Fibrous bark%	Spun fiber%
SS-15A	2SB-10	9,60	4,42	1,14	0,93	0,69	1,01	0,07
UXK DPZ-180								
MKO new SS-15A								
2SB-10	UXK DPZ-180	4,50	2,85	0,96	0,91	0,65	0,98	0,05

The technological process of the ginning industry was carried out according to the sequence scheme, selection and industrial varieties S-6524 II / 2 according to the guidelines for determining the quality of cotton fiber from production and determined on the basis of the following tables and graphs Table 3.13. Selection variety S-6524, industrial grade second grade, initial contamination rate of second grade cotton raw material -9.6%; humidity level-10.5%. Prior to washing, the cleaning efficiency was 4.5% when the cleaning process was performed on the newly introduced device, i.e. the cleaning efficiency was 53.1%. (Figure 1.4). After the cleaning process of S-6524 II / 2 industrial grade cotton, the amount of fine defects is cleaned from 4.42% to 2.85%, the total amount of fine impurities is from 1.14% to 0.96%, the amount of fibrous fiber is from 0.93% to 0.91%, the amount of broken seeds is from 0.69% to 0.65%, The decrease in fiber seed husk from 1.01% to 0.98%, the amount of spun fiber from 0.07% to 0.05%, the increase in the quality of fiber products was determined on the basis of the analysis.

Table 4. Structural quality indicators of cotton fiber obtained from production according to the sequence scheme of the technological process

Sequence diagram of the technological process		Composite quality indicators of cotton fiber obtained from production						
		Breeding and industrial grade And-35 III / 2						
		Starting pollution, %	Total defects,%	Minor pollution%	Ulyuk %	Broken seeds %	Fibrous bark%	Spun fiber %
SS-15A	2SB-10	11,90	5,19	1,19	1,16	0,83	1,28	0,12
UXK DPZ-180								
MKO new SS-								
15A	2SB-10 UXK DPZ-180	5,40	3,46	1,05	0,98	0,76	1,06	0,09



Selection variety And-35, industrial grade third grade, initial contamination rate of second grade cotton raw material 11.9%; humidity level 13.5%; Before cleaning, the cleaning efficiency in the newly introduced device was 5.4%, ie the cleaning efficiency was 54.6%. The results of the comparative study show that after the cleaning process of And-35 III / 2 industrial grade cotton, the amount of fine defects is 5.19% to 3.46%, the amount of fine impurities is 1.19% to 1.05%, the amount of fibrous fiber is 1.16% to 0.98%, the amount of broken seeds is 0.83. from 0.76 percent, fibrous seed husk from 1.28 percent to 1.06 percent, and the amount of spun fiber from 0.12 percent to 0.09 percent, which led to an increase in the quality of fiber products.

Table 5. Composite quality indicators of cotton fiber obtained from production

Sequence diagram of the technological process	Composite quality indicators of cotton fiber obtained from production Breeding and industrial grade And-35 IV / 2						
	Starting pollution	Total defects %	Minor pollution	Ulyuk %	Broken seeds %	Fibrous bark%	Spun fiber %
	%	%	%				
SS-15A 2SB-10 UXK DPZ-180	15,50	8,63	2,45	1,87	1,36	2,14	0,23
MKO new SS-15A 2SB-10 UXK DPZ-180	6,80	4,94	1,67	1,63	1,21	1,90	0,16

Breeding and industrial grade And-35 IV / 2

Selection variety And-35, industrial grade fourth grade, second grade cotton raw material has an initial contamination rate of 15.5% and a moisture content of 13.5%. Before cleaning, the cleaning efficiency of the newly introduced device was 6.8%, ie the cleaning efficiency was 56.1%. The results of the comparative research test show that after the cleaning process of And-35 IV / 2 industrial grade cotton, the amount of fine defects is 8.63% to 4.94%, the amount of fine impurities is 2.45% to 1.67%, the amount of fiber is 1.87% to 1.63%, the amount of broken seeds is 1.36. Based on the analysis, it was found that the quality indicators improved due to a decrease of 1.21 percent.

The results of a comparative study obtained during the technological treatment of raw and unpolluted cotton from the Garam area are given above. The device, which was introduced into production in a new design, allows to carry out pre-ginning cleaning of cotton, the use of new technology in ginning plants, the loss of raw materials while maintaining the quality of cotton products within the norm, reducing fuel and electricity consumption and ensuring a high level of revenue from the sale of fiber at the end of production.



Table 6. The new device shows the effect of the distances between the saw drum and the ribbed grids on the cleaning efficiency and quality level of the cotton.

Selection and industrial variety	Cotton pollution level %	The distance between the saw and the ribbed device	work efficiency, t / s	Device cleaning efficiency %	The amount of raw cotton in the waste,%	The amount of raw cotton in the waste, relative to the total amount of ginned cotton, %	Mechanical damage to seeds %
S-6524 II / 2	8.3	12-14	3.0	48	4.4	0.1	1.98
	9.6	14-16	3.0	53.1	4.5	0.3	1.99
	9.4	16-18	3.0	55.3	4.7	0.2	1.97
And-35 III/2	11.5	12-14	2.8	51.3	4.8	0.4	3.81
	11.9	14-16	2.8	54.6	4.9	0.5	3.85
	11.7	16-18	2.8	55.5	4.9	0.6	3.86
Анд-35 IV/2	14.7	12-14	2.5	51.0	5.3	0.5	
	14.7	14-16	2.5	56.1	5.6	0.6	5.15
	15.5	16-18	2.5	55.7	5.5	0.5	5.19

In summary, after cleaning processes of industrial varieties S-6524 II / 2, And-35 III / 2, And-35 IV / 2, it was found that the cleaning efficiency from small, large and general defects is high.

On the basis of a small sample of cotton fiber, the traditional methods of testing using a tool were identified, in which a test sample was obtained by repeatedly averaging and reducing the number of samples selected from different locations after fiber cleaning machines. These methods are used in the assessment of the quality of cotton fiber, in the work of breeders, cotton gins and textile enterprises in the quality control of products in the technological process [22-26]. The following table shows the methods for determining the fiber quality of fiber products obtained from production in the laboratory system HVI 900 SA of Namangan regional laboratory by length, toughness, elongation at break, micronaire, color and contamination.

Table 7. Republican Center for Certification of Cotton Fiber "Sifat", Namangan regional laboratory Results of production of fiber products in the laboratory system HVI 900 SA

Selection and industrial grade	High average length (UHML) mm, inch	Micronaire Indicator (Mic),%	Specific tensile strength Strength (Str), cN / tex	Light reflection coefficient Reflectance (Rd),%	Yellowness Rate Yellowness + b),	Tresh code Trash Code (T),%	Short fiber index (SFI) mm	Long same Index (Unf)%
And-35 III/2	(28.7)1.13	5.2	37.8	66.5	8.0	13	9.8	82.8
And-35 III/2	(28.9)1.14	5.1	36.9	66.3	8.2	19	12.2	81.6
And-35 III/2	(28.1)1.11	5.2	39.1	67.7	7.9	11	8.1	83.6
And-35 III/2	(28.8)1.14	5.2	35.9	66.1	8.6	18	9.8	83.5
And-35 III/2	(29.8)1.17	4.9	39.7	66.6	7.7	14	7.0	83.4
And-35 III/2	(28.0)1.10	5.0	35.4	67.6	7.8	15	13.3	81.0
S6524 II/2	(29.8)1.17	5.1	43.1	67.4	8.3	13	7.9	84.0
S6524 II/2	(29.6)1.16	4.9	41.1	69.9	7.4	13	8.9	83.5
S6524 II/2	(29.3)1.15	4.9	39.2	68.7	7.6	10	10.8	83.3
S6524 II/2	(29.8)1.17	4.9	41.2	70.7	7.3	15	13.3	81.0
S6524 II	(29.3)1.15	5.0	39.3	67.5	7.6	9	10.2	83.1



Conclusions

Studies have shown that during the movement of raw materials along the mesh surface, a contact force is formed between the organic particles in the cotton and the mesh surface, under the influence of which a flash occurs, resulting in reduced productivity and a negative impact on cotton quality. Proper organization and introduction of equipment in the technological process will reduce the level of damage to raw cotton, which will significantly increase the economic efficiency of the enterprise. In addition, uniformity in Unf-length indicates a decrease in short fibers in the free fiber content, an increase in specific tensile strength, and an increase in Elg-length elongation.

References

1. A.G.Sevostyanov Modeling of technological processes. M. Legkaya and pishchevaya promyshlennost,1984, 344 p.
2. Yu.Ergashev X.Turdiyev N.Oripov.Sh Xusanova. (2018). Chigitli paxtani mayda iflosliklardan tozalash texnologiyasini takomillashtirish Ilmiy-amaliy anjumani.
3. A.Yu.Ishlinskiy. (1986). Prikladnye zadachi mechanics. M. Nauka. 366 s.
4. Korabelnikov A.R. and dr. Vydelenie sornyx primesey s poverxnosti sloya voloknistogo materiala. Journal "Technology of textile industry", №4 (340), 2012.
5. Sevostyanov A.G. Methods and means of studying mechanical and technological processes of textile industry. Moscow »Light industry». 1980.g
6. Zikriyoev E.Z. Textbooks under the general editorship. Primary processing of raw cotton, Tashkent. Labor, 1999, pp. 258-269.
7. R.Muradov. (2005). Ways to improve the efficiency of the cotton separator. Namangan edition, pp. 62-63.
8. Jahongir, S., Raimovich, F. S., Mirzohid, R., & Husanhon, B. (2021). The effect of the cylinder rotation frequency on the carding machine on the sliver and the yarn quality. Scientific and technical journal of NamIET, 6, 149-155.
9. Toshtemirov, Q. A., & Oripov, N. M. (2021). Improvement of ring spinning machine stretching equipment. Innovative Technologica: Methodical Research Journal, 2(10), 61-66.
- 10.Oripov, N., Komilov, J., Xolikova, Z., & Toshmirzaevk, O. Research on the Introduction of a Double-faced Improved Cotton Separator. International



- Journal of Innovations in Engineering Research and Technology, 7(12), 105-110.
11. Isaev, S. S., Yu, E., Oripov, N., & Xakimov, I. Study of the Effect on the Natural Characteristics of Fiber in the Process of Application of Cotton Processing Technology. *International Journal of Innovations in Engineering Research and Technology*, 7(12), 111-116.
 12. Mo'minovich, U. M. (2021). The Importance Of Planting And Processing Of Medium-Field Cotton Varieties Between Cotton Rows In Fergana Region. *The American Journal of Agriculture and Biomedical Engineering*, 3(09), 26-29.
 13. Бекмирзаев, Ш., Саидмахаматов, Н., & Убайдуллаев, М. (2016). Получения Литье В Песчано-Глинистые Методом. *Теория и практика современной науки*, (6-1), 112-115.
 14. Ubaydullayev, M. M., Ne'matova, F. J., & Marufjonov, A. (2021). Determination of efficiency of defoliation in medium-fiber cotton varieties. *Galaxy International Interdisciplinary Research Journal*, 9(11), 95-98.
 15. Кодиров, З. З., Ирискулов, Ф. С., Пулатов, А., & Убайдуллаев, М. (2018). Electronic libraries as a fact of contemporary information landscape. *Экономика и социум*, (3), 629-633.
 16. Тешаев, Ф. Ж., & Убайдуллаев, М. М. (2020). Определение эффективных норм новых дефолиантов в условиях лугово-солончаковых почв Ферганской области при раскрытии коробочек 50-60% сортов хлопчатника с8290 и с6775. *Актуальные проблемы современной науки*, (5), 62-64.
 17. Ubaydullaev, M. M. U., Askarov, K. K., & Mirzaikromov, M. A. U. (2021). Effectiveness of new defoliants. *Theoretical & applied science Учредители: Теоретическая и прикладная наука*, (12), 789-792.
 18. Ubaydullayev, M. M. (2021). G 'o 'zada defoliatsiya o 'tkazishning maqbul me'yor va muddatlari. *Monografiya.-Corresponding standards and terms of defliation of cotton. Monograph.-. Соответствующие нормы и сроки дефолиации хлопка. Монография. Zenodo.*
 19. Ubaydullaev, M. M. (2020). The importance of sowing and handling of c-8290 and c-6775 seeds in the conditions of the meadow soils of the Fergana area. In *International conference on multidisciplinary research* (p. 11).



20. Омонова, М. С., & Ибрагимова, Г. О. (2019). Влияние обработки семян хлопчатника на физико-химические показатели получаемого масла. *Universum: технические науки*, (11-1 (68)), 78-81.
21. Yakubjanovna, B. D. (2022). The modern methods of processing missella. *Innovative Technologica: Methodical Research Journal*, 3(01), 76-85.
22. Qodirovich, Y. O., Yakubzhanovna, B. D., & Kodirov, Z. Z. (2021). Research of hydrogenization of soybean oil. *Innovative Technologica: Methodical Research Journal*, 2(11), 94-100.
23. Усманов, Б. С., Гоппиржонович, Қ. М., Сайтбековна, Қ. У., & Умурзакова, Ш. М. (2019). Особенности состава и свойств сафлорового соапстока, определяющие области его применения. *Universum: технические науки*, (12-3 (69)), 18-20.
24. Хакимов, М. У., & Умурзакова, Ш. М. (2021). Определение Содержания Воды В Моркови В Продуктах Питания. *Central Asian Journal Of Theoretical & Applied Sciences*, 2(12), 60-63.
25. Umurzakova, S., & To'lanova, Z. (2022). The quality of wheat grains and the process that affects their storage. *American Journal Of Agriculture And Horticulture Innovations*, 2(05), 09-18.
26. Ортикова, С. С., Хокимов, А. Э. У., & Нурматова, З. Н. К. (2019). Изучение химического состава аммофосфата, полученного на основе фосфорнокислотной переработки забалансовой фосфоритной руды Центральных Кызылкумов. *Universum: химия и биология*, (12 (66)), 56-58.