



ANALYSIS OF RUNNERS AND SPINNERS USED IN SPINNING MACHINES

Toshtemirov Qosimjon Abdulhayevich
Assistant, Department of Natural Fibers,
Fergana Polytechnic Institute, Fergana, Uzbekistan

Abstract

The demand for spinning technology, one of the main production processes in the textile industry, is growing. This is due to the high demand for materials that meet delicate technical requirements. The article discusses the details used in spinning machines and their technological processes.

Keywords: spinning technology, textile industry, loops and threads

Introduction

The parts of a spinning machine have very complex geometric shapes, and some parts are capable of working at high speeds. Such details include runners and threaders. These two parts are part of the quality of the spinning process.

Currently in production in two groups:

- Elliptic
- C-shaped runners are used.

In the manufacture of treadmills, its geometric dimensions must correspond to the profile of the ring. The service life of the kneader depends on the material from which it is made, the working conditions and the timely maintenance of the knitting machine [1,2]. The choice of yarn is important because the product of the spinning process affects the quality of the yarn. Basically, a flat winding of the yarn and maintaining its density also reduces the breakage of the yarn during the winding process. The number of yarns is selected depending on the range of yarn numbers. Because the runners run at high speeds, their design has been improved to prevent them from overheating [3,4].

The Main Part

Rolls and Spinners. The ring plays a role in the cooking and winding of the yarn. Kneaders are one of the main organs of the cooking mechanism. It is in the form of a

bracket and is made of steel wire. Rolls are produced in two types C-shaped (a) and elliptical (b). In addition, the cross-section of the yoke may vary (c) [5,6]. The mass in grams of a thousand rolls indicates its number [7-10]. The smaller the diameter of the tube, the thinner the yarn, the higher the speed of rotation of the spools, and the larger the diameter of the loop, the lighter the runner. The running time of the treadmills is 150-200 hours, and they are regularly replaced according to a special schedule.

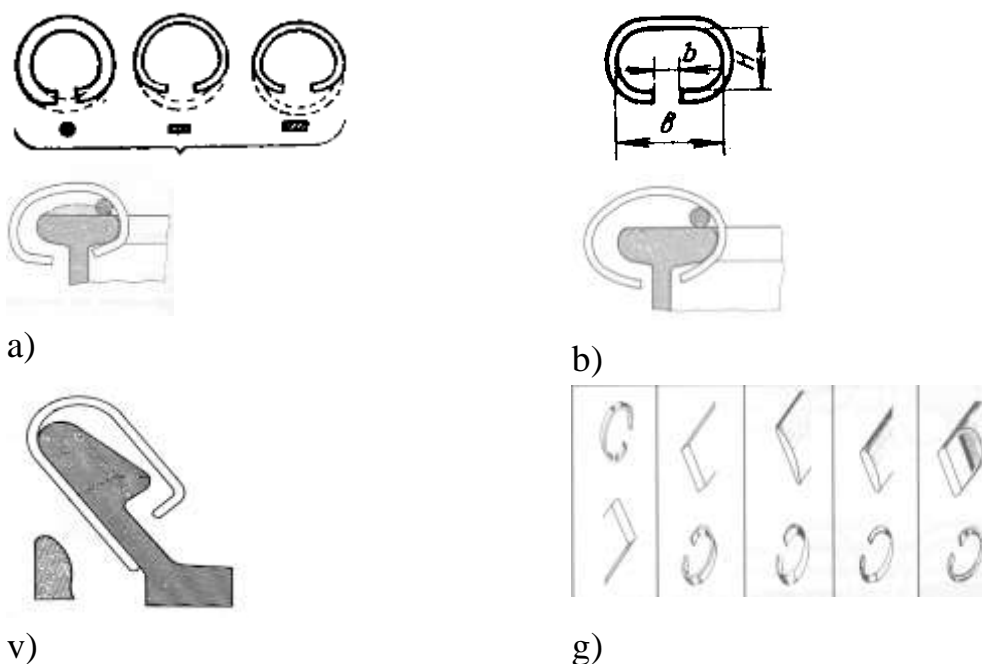

Figure 1. Types of rolls, a) C-shaped, b) elliptical, c) shaped, d) different cross-sectional rolls.

Threads. Threads are used to hold the thread coming out of the stretcher in a vertical direction to the axis of the thread. The conductors are fastened at an angle parallel to the cylindrical beam 1 of loop 2 made of steel wire. It is mounted perpendicular to the axis of thread 3 by means of a suspension 4 passed through the loop of the thread. A template 5 is mounted on the hinge to ensure that the end of the hanger is aligned with the centre of the arrowhead. The yarn is then cooked well and the baking process is normal (Figure 2).

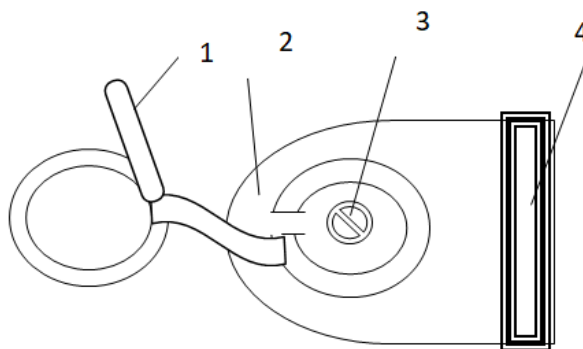

Figure 2. Yarn conductors

Another function of yarn conductors is that they hold the balloon (curve) formed during the yarn baking process at the same height and at the same tension. As the thread is tightened, the ring bar of the machine rises and falls. The balloon is small (short) when the ring bar is raised and large (long) when it is lowered. Experiments have shown that the minimum cylinder is 52 mm and the maximum is 214 mm. As a result, the tension of the yarn varies during cooking, which breaks a lot and reduces the efficiency of the machine.

Another function of the thread conductors is that it holds the end of the thread when it is broken, otherwise it will be more difficult to hold the broken thread. The end of the string is caught in the groove at the end of the thread loop. In the manufacture of treads, its geometric dimensions must correspond to the profile of the ring. The service life of the kneader depends on the material from which it is made, the working conditions and the timely maintenance of the knitting machine. The choice of yarn is important because the product of the spinning process affects the quality of the yarn. Basically, wrapping the yarn evenly and keeping it tight also reduces the loss of yarn during the wrapping process. The number of yarns is selected depending on the range of yarn numbers. Because the runners run at high speeds, their design has been improved to prevent them from overheating. The spinning and running ropes are very important during the spinning process. Nowadays, fixed wires are mainly used, but these wires have their own disadvantages. Most of them have the ability to pass the incoming thread at the same rate and sometimes pass the defective threads. To overcome these shortcomings, a movable wire structure will be developed.



References

1. S.R.Marasulov. (1985). The spinning of cotton and chemical fibres. Section VI. Tashkent. "Teacher."
2. Makhmudovna, N. M., & Mukhammadkarim, M. (2021). The importance of improving technological processes for storage and processing of dry cocoons grown in different seasons. *International Engineering Journal for Research & Development*, 6(3), 3-3.
3. Набиев, К. К., Якубов, Н. Ж., & Ниязалиева, М. М. (2019). Пути повышения надёжности нити при стачивании швейных изделий. *Вестник науки и образования*, (20-3 (74)).
4. Oripov, N., Komilov, J., Xolikova, Z., & Toshmirzaevk, O. Research on the Introduction of a Double-faced Improved Cotton Separator. *International Journal of Innovations in Engineering Research and Technology*, 7(12), 105-110.
5. Adiljonovich, T. I. (2020). Influence of industry 4: 0 program on ensuring country competitiveness in the international market. *ACADEMICIA: An International Multidisciplinary Research Journal*, 10(5), 730-736.
6. Mamajonov Hamidjon, N., & Toshpulatov Ikboljon, A. (2019). Improvement of light industry enterprises and competitiveness of management system. *Инновационными и инвестиционными процессами и изменениями в условиях цифровой экономики Сборник научных трудов*, 118.
7. Kurbonaliyeva, I. G., & Adxamovna, B. G. (2021). The main causes of conflicts in higher educational institutions and the concept of their management. *Asian Journal Of Multidimensional Research*, 10(6), 239-244.
8. Kurbonaliyeva, I. G., & Adxamovna, B. G. (2021). Innovative solutions for effective conflict resolution in higher education institutions. *South Asian Journal Of Marketing & Management Research*, 11(6), 33-37.
9. Валиев, Г. Н. (2016). Пространственное распределение угла подъёма витка намотки мотальной паковки. In *Дизайн, технологии и инновации в текстильной и легкой промышленности (Инновации-2016)* (pp. 36-40).
10. Zikirov, M. C., Qosimova, S. F., & Qosimov, L. M. (2021). Direction of modern design activities. *Asian Journal of Multidimensional Research (AJMR)*, 10(2), 11-18.