



ADJUSTMENT OF THE IMPROVED CHIZEL-CULTIVATOR TO THE DETERMINED DEPTH

Sarimsakova Shahodatkhon Toshpulatovna

Assistant, Andijan Institute of Agriculture and Agrotechnology

ABSTARCT

The development and application of energy-efficient, high-performance and high-quality pre-sowing tillage machines is a world leader. [1] "Today, the world spends \$ 1.8 billion annually on sowing the seeds of agricultural crops. Given that the area is cultivated per hectare, the machines used in pre-sowing tillage should be energy-efficient, high-quality and productive. In this regard, it is important to improve the techniques used in pre-sowing tillage on a scientific basis. Targeted research is being carried out around the world to create resource-saving technologies for the preparation of fields for sowing of agricultural crops and new models of equipment, to develop scientific and technical bases for improving existing ones, to ensure resource efficiency in the work process. [2]

This research was carried out in accordance with the priorities of the development of science and technology of the republic "Energy, energy and resource conservation." In world practice, various devices and technical means have been developed to increase the efficiency of pre-planting tillage processes. They were recommended to design bureaus to create new machines. J.Ba laton, Spoor Gordon (Germany), R.Blackstein, J.V. have been working abroad to increase the agro-technical performance and productivity of chisel-cultivators and similar equipment, reduce energy consumption. Stafford, A.Geiki (England), K.Araya, K.Kawanishi, R.Soucek, S.Anisch, S.Woif (USA), I.M.Panov, N.M.Orlov, G.V.Plyushchev, Research work was carried out by G.M. Prokopenko, V.A. Lim, D.A. Tryapitsin, V.I. Vetoxin (Russian Federation) and other scientists. Research in this direction in our country GM Rudakov, RI Boymetov, FM Mamatov, A. Tokhtako'ziev, IT Ergashev, BS Mirzaev, QB Imamkulov, H. Begimov, M. Performed by Mirakhmatov, AA Nasriddinov, FU Juraev and others. The pre-sowing tillage machines created as a result of these studies are being used in agricultural production with some positive results. [7] However, these studies are mainly focused on the development of pre-planting tillage technologies and equipment, which do not adequately study the issues of reducing the energy consumption of existing chisel cultivators, improving agro-technical performance and productivity.

The purpose of the study is to increase the quality and productivity of pre-sowing tillage and reduce energy consumption due to technical and technological improvements of existing chisel cultivators. [8]

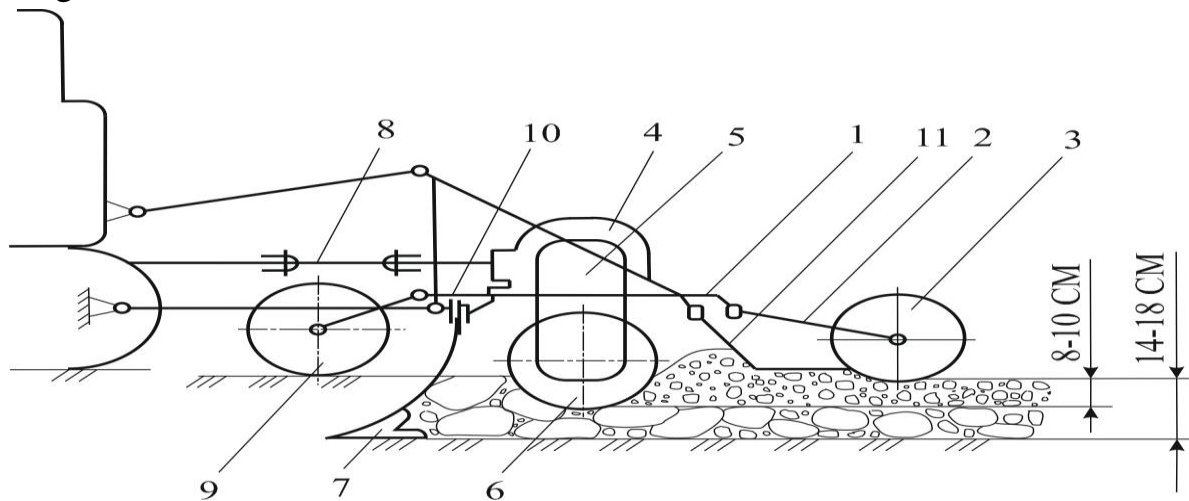

Frame of device 1; 2- tortqi; 3- reel; 4 central reducer; 5-way reducer; 6- rotor; 7 softening working body; 8-cardan shaft; 9 base wheels; 10 support wheel mounting bracket; 11- straightening apron. [9]

Chisel-cultivator with a working part that softens the spring column

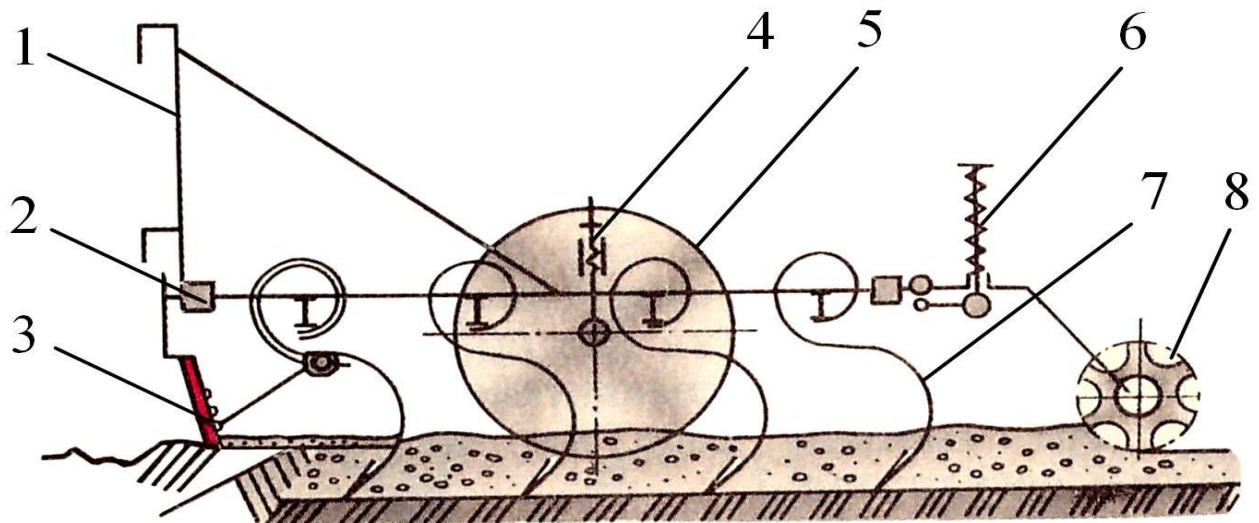

1-hanging device; 2-frame; 3 levelers; 4 machining depth adjusting screw; 5 support wheel; 6 pressure spring; 7 softening working body; 8-reel reel.

KM-3.0 combined machine



1-rama; 2- fertilizer spreader; 3- base wheel; 4-5- soil softening working bodies; 6- soshnik; 7- leveler; 8-toothed-plank reel.

Working bodies of the chisel cultivator

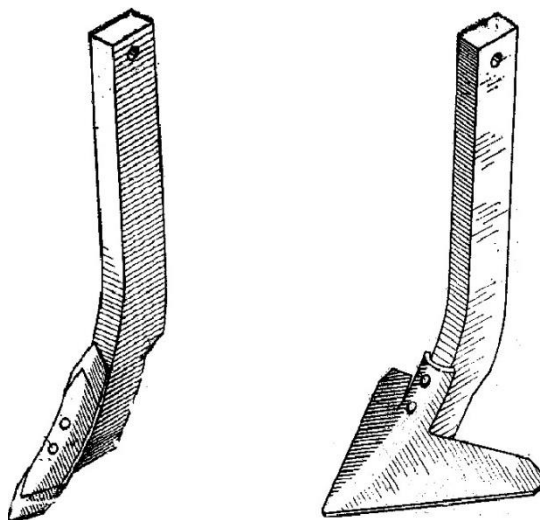

a - softening claw;

b is the occlusal claw;



Conclusion

The vertical distance from the base plane of the chisel cultivator to the lower hanging points should be in the range of 50-60 cm in order to ensure that the improved chisel [10] cultivator sinks to the specified depth and stays stable at this depth and provides the required level of transport clearance.

LITERATURE

- 1) Standard technological maps for the care and cultivation of agricultural crops. For 2016-2020 (Part I). - Tashkent, 2016. - 138 p.
- 2) Tokhtako'ziev A., Toshpulatov B.U. Advanced chisel-cultivator // Proceedings of the scientific-practical conference "Science and Technology, Education and Technology: Current Problems and Development Trends" (Part 2). - Jizzax, 2017. - Б. 337-339
- 3) Синеоков Г.Н., Панов И.М. Теория и расчет почвообрабатывающих машин. – Москва: Машиностроение, 1977. – 328 с.
- 4) Соколов Ф.А. Агронимические основы комплексной механизации хлопководства. – Ташкент: Фан, 1977. – 244 с.
- 5) ГОСТ 10677-2001 “Устройство навесное заднее сельскохозяйственных тракторов синфров 0,6-8. Типы, основные параметры и размеры”. – Минск, 2001. – 10 с.
- 6) Кленин Н.И., Сакун В.А. Сельскохозяйственные и мелиоративные машины. – Москва: Колос, 2005. – 671 с.
- 7) ТС Худойбердиев, ШН Нурматов, БР Болтабоев, МШЎ Холдаров, “НОВАЯ КОНСТРУКЦИЯ УНИВЕРСАЛЬНОГО КОМБИНИРОВАННОГО КУЛЬТИВАТОРА УДОБРИТЕЛЯ”. //Life Sciences and Agriculture//. 2021. <https://cyberleninka.ru/article/n/novaya-konstruktsiya-universalnogo-kombinirovannogo-kultivatora-udobritelya>
- 8) TS Xudoyberdiev, BR Boltaboev, BA Razzakov, MS Kholdarov. //To the fertilizer knife determination of resistance//. Asian Journal of Multidimensional Research (AJMR) 9 (8), 65-71. <https://www.indianjournals.com/ijor.aspx?Target=ijor:ajmr&volume=9&issue=8&article=011>
- 9) МШ Холдаров. “УНИВЕРСАЛЬНО-КОМБИНИРОВАННЫЙ КУЛЬТИВАТОР УЛУЧШЕННАЯ КОНСТРУКЦИЯ УДОБРЕНИЯ”. //INTERNATIONAL JOURNAL OF DISCOURSE ON INNOVATION,



INTEGRATION AND EDUCATION//. 2020. <http://summusjournals.com/index.php/ijdiie/article/view/355>

- 10) ТС Худойбердиев, БР Болтабоев, БН Турсунов, ООЎ Абдуллаев. “ПРИМЕНЕНИЕ НУЛЕВОГО СПОСОБА ОБРАБОТКИ ПОЧВЫ ПРИ ПОСЕВЕ КУКУРУЗЫ В КАЧЕСТВЕ ПРОМЕЖУТОЧНОЙ КУЛЬТУРЫ”. //Life Sciences and Agriculture//. 2021 <https://cyberleninka.ru/article/n/primenenie-nulevogo-sposoba-obrabotki-pochvy-pri-poseve-kukuruzy-v-kachestve-promezhutochnoy-kultury>.